



**SIDDHARTH GROUP OF INSTITUTIONS :: PUTTUR
(AUTONOMOUS)**

Siddharth Nagar, Narayanavanam Road – 517583

QUESTION BANK (DESCRIPTIVE)

Subject with Code : Analog Circuits (18EC0407)

Course & Branch: B.Tech - ECE

Year & Sem: II-B.Tech & II-Sem

Regulation: R18

UNIT –I

SMALL SIGNAL HIGH FREQUENCY TRANSISTOR AMPLIFIER ANALYSIS AND MULTISTAGE AMPLIFIERS

I. Two Mark Questions:

1. Why h-parameter model is not suitable for high frequencies? [L1][CO1][2M]
2. Draw the Hybrid π Common Emitter transistor model for high frequencies. [L1][CO1][2M]
3. Define the cutoff frequency f_{α} and write down its expression. [L2][CO1][2M]
4. What is cutoff frequency, f_{β} and write down its expression. [L2][CO1][2M]
5. Define unity gain frequency, f_T . [L1][CO1][2M]
6. Classify the coupling types. [L1][CO1][2M]
7. Mention the applications of a transformer coupling technique. [L1][CO1][2M]
8. What is cascode amplifier? [L1][CO1][2M]
9. Mention the advantages of Darlington pair amplifier. [L1][CO1][2M]
10. If four identical amplifiers are cascaded each having $f_L = 100$ Hz, determine the Overall lower 3dB frequency f_L . Assume non – interacting stages. [L3][CO1][2M]

II. Part – B Questions:

1. a) Draw the Hybrid- π model and explain the significance of each and every component in it. [L2][CO1][5M]
b) Derive the expression for Hybrid- π capacitance of CE transistor at high frequency. [L2][CO1][5M]
2. Derive the expression for the hybrid- π parameters g_m , $g_{b'e}$, $g_{b'c}$, $r_{bb'}$ and g_{ce} . [L2][CO1][10M]
3. a) Describe the variation of hybrid- π parameters upon collector current, V_{CE} and Temperature. [L2][CO1][5M]
b) At $I_c = 1$ mA and $V_{CE}=10$ V, a certain transistor data shows $C_c = C_{b'c} = 3$ pF, $h_{fe} = 200$ and $w_T = -500$ M rad/sec. Calculate g_m , $r_{b'e}$, $C_e = C_{b'e}$ and w_{β} . [L3][CO1][5M]
4. With the help of necessary circuit diagrams and approximations obtain the expression for CE short circuit current gain and derive the relation between f_{β} and f_T . [L2][CO1][10M]
5. Obtain the expression for Current gain with resistive load and discuss the variation of frequency response with R_L . [L2][CO1][10M]
6. a) Short circuit CE current gain of a transistor is 25 at a frequency of 2MHz. If $f_{\beta} = 200$ KHz Calculate (i) f_T (ii) h_{fe} (iii) Find $|A_i|$ at frequency of 10MHz and 100MHz. [L3][CO1][5M]
b) A BJT has $g_m = 38$ mhos, $r_{b'e} = 5.9$ k Ω , $h_{ie} = 6$ k Ω , $r_{bb'} = 100$ Ω , $C_{b'c} = 12$ pF, $C_{b'e} = 63$ pF and $h_{fe} = 224$ at 1 KHz. Calculate α , β cutoff frequencies and f_T . [L3][CO1][5M]
7. Describe different methods used for coupling of multistage amplifiers with their frequency response. [L2][CO1][10M]
8. Draw the block diagram of n-stage cascaded amplifier and analyze its various parameters. [L4][CO1][10M]
9. With neat diagram, explain Cascode amplifier and derive the overall voltage gain, input resistance, current gain and output resistance of cascode amplifier. [L2][CO1][10M]
10. a) What is Darlington Connection? [L1][CO1][2M]
b) With diagram, derive the expression for current gain and input resistance of Darlington amplifier. [L2][CO1][8M]

11. For the circuit shown in Fig. Calculate R_i , A_i , A_v and R_o if the h – parameters are $h_{ie}=1.1k\Omega$, $h_{fe}=50$, $h_{oe} = 25\mu A/V$ and $h_{re} = 2.5 \times 10^{-4}$. [L3][CO1][10M]

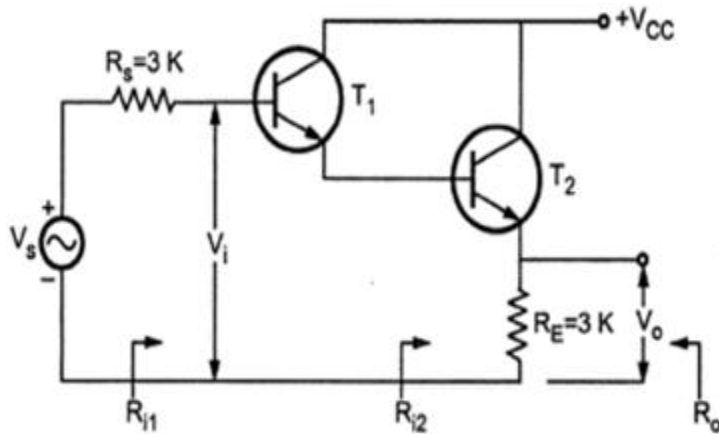

12. a) Explain the effect of cascading on bandwidth of multistage amplifier. [L2][CO1][6M]
 b) If the overall lower and higher cutoff frequencies of a two identical amplifier cascade are 600 Hz and 18 kHz respectively, compute the values of individual cutoff frequencies of both the amplifier stages. [L3][CO1][4M]

UNIT –II

FEEDBACK AMPLIFIERS AND OSCILLATORS

I. Two Mark Questions:

1. Define feedback. [L1][CO2][2M]
2. What is positive feedback and negative feedback? [L1][CO2][2M]
3. Classify various types of basic amplifiers. [L2][CO2][2M]
4. Compare the performance of various feedback amplifiers. [L2][CO2][2M]
5. An amplifier has an open loop gain of 1000 and feedback ratio of 0.04. If the open loop gain changes by 10% due to temperature, find the percentage change in gain of the amplifier with feedback. [L3][CO2][2M]
6. State Barkhausen criterion for oscillation. [L1][CO2][2M]
7. Mention the different types of oscillators. [L2][CO2][2M]
8. What are the applications of oscillators? [L1][CO2][2M]
9. Mention the disadvantages of RC Phase shift oscillator. [L1][CO2][2M]
10. In a Colpitts oscillator, $L = 40mH$, $C_1 = 100pF$ and $C_2 = 500pF$. Determine its frequency of oscillation. [L3][CO2][2M]

II. Part – B Questions:

- 1.a) Explain the concept of negative feedback with the help of a neat block diagram. [L2][CO2][6M]
 b) With neat diagram, discuss voltage amplifier and current amplifier. [L2][CO2][4M]
2. Describe the characteristics of negative feedback amplifiers. [L2][CO2][10M]
3. a) Derive the expressions of input and output resistances for Voltage Series FBA. [L2][CO2][6M]
 b) A voltage series negative feedback amplifier has a voltage gain without feedback of $A = 500$, input resistance $R_i = 3k\Omega$, output resistance $R_o = 20k\Omega$ and feedback ratio $\beta = 0.01$. Calculate the voltage gain A_f , input resistance R_{if} , and output resistance R_{of} of the amplifier with feedback. [L3][CO2][4M]
4. a) Determine the input and output resistances of Current Shunt feedback amplifier. [L2][CO2][6M]
 b) An amplifier has a voltage gain of 400, $f_1 = 50$ Hz, $f_2 = 200kHz$ and a distortion of 10% without feedback. Determine the amplifier voltage gain, f_{1f} , f_{2f} and D_f when a negative feedback is applied with feedback ratio of 0.01. [L3][CO2][4M]
5. a) Derive the expressions of input and output resistances for Voltage Shunt FBA. [L2][CO2][5M]
 b) Determine the input and output resistances of Current Series feedback amplifier. [L2][CO2][5M]

6. a) Explain the analysis of negative feedback amplifier. [L2][CO2][6M]
 b) An amplifier has voltage gain with feedback of 100. If the gain without feedback changes by 20% and the gain with feedback should not vary more than 2%, determine the value of open loop gain A and feedback ratio β . [L3][CO2][4M]
7. With the help of a neat circuit diagram, discuss RC phase shift oscillator using BJT and also derive the expression for its frequency of oscillations. [L2][CO2][10M]
8. Describe the working principle of Wein bridge oscillator and derive the expression for frequency of oscillations. [L2][CO2][10M]
9. a) Explain the general analysis of an LC Oscillator. [L2][CO2][8M]
 b) In an RC phase shift oscillator, if $R_1 = R_2 = R_3 = 200\text{k}\Omega$ and $C_1 = C_2 = C_3 = 100\text{pF}$. Find the frequency of oscillation. [L3][CO2][2M]
10. a) With the help of a neat circuit diagram, discuss Hartley oscillator using BJT and also derive the expression for its frequency of oscillation. [L2][CO2][8M]
 b) In the Hartley oscillator, $L_2 = 0.4\text{mH}$ and $C = 0.004\mu\text{F}$. If the frequency of oscillator is 120kHz, find the value of L_1 . Neglect the mutual inductance. [L3][CO2][2M]
11. a) Describe the working principle of Colpitts oscillator and derive the expression for frequency of oscillations. [L2][CO2][8M]
 b) In the Colpitts oscillator, $C_1 = 0.2\mu\text{F}$ and $C_2 = 0.02\mu\text{F}$. If the frequency of oscillation is 10kHz, find the value of inductor. [L3][CO2][2M]
12. Write notes on the following:
 a) Crystal oscillators [L1][CO2][5M]
 b) Frequency and amplitude stability of oscillators. [L1][CO2][5M]

UNIT III POWER AMPLIFIERS & TUNED AMPLIFIERS

I. Two Mark Questions:

1. Classify different types of power amplifiers. [L1][CO3][2M]
2. Compare the various types of power amplifiers. [L1][CO3][2M]
3. Mention the disadvantage of series fed direct coupled class A power amplifier. [L2][CO3][2M]
4. What are the differences between Push Pull and Complementary symmetry class B power amplifier? [L1][CO3][2M]
5. What is crossover distortion? [L1][CO3][2M]
6. What is a tuned amplifier? [L1][CO3][2M]
7. Mention the different types of tuned amplifiers. [L1][CO3][2M]
8. In a tuned amplifier $L = 100\mu\text{H}$ and $C = 100\text{pF}$. Determine its resonant frequency. [L3][CO3][2M]
9. Give the applications of tuned amplifiers. [L1][CO3][2M]
10. What is stagger tuned amplifier? [L1][CO3][2M]

II. Part – B Questions:

- 1.a) With neat diagram explain Series fed, Directly coupled Class A Power Amplifier and derive its maximum efficiency. [L2][CO3][5M]
- b) A series fed Class A amplifier shown in Fig. operates from dc source and applied sinusoidal input signal generates peak base current 9mA. Calculate : (i) Quiescent current I_{CQ} , (ii) Quiescent voltage V_{CEQ} , (iii) DC input power P_{DC} , (iv) AC output power P_{AC} and (v) Efficiency. [L3][CO3][5M]

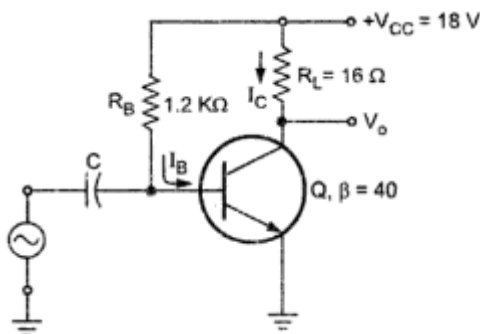

2. The loudspeaker of 8Ω is connected to the secondary of the output transformer of a class A Amplifier. The quiescent collector current is 140mA. The turns ratio of transformer is 3:1. The collector supply voltage is 10V. If ac power delivered to the loudspeaker is 0.48W, assuming ideal transformer, calculate (i) AC power developed across primary, (ii) RMS value of load voltage, (iii) RMS value of primary voltage, (iv) RMS value of load current, (v) RMS value of primary current, (vi) DC power input, (vii) efficiency and (viii) power dissipation. [L3][CO3][10M]
3. a) Discuss with diagram, Transformer coupled Class A Power Amplifier and derive its Maximum efficiency. [L1][CO3][5M]
 b) A Class B push pull amplifier drives a load of 16Ω , connected to the secondary of ideal transformer. The V_{cc} is 25V. If number of turns on primary is 200 and secondary is 50. Calculate maximum power output, DC power input and efficiency. [L3][CO3][5M]
4. With neat diagram explain the working principle of Push Pull Class B Power Amplifier and derive its maximum efficiency. [L2][CO3][10M]
5. a) Describe Complementary Symmetry Class B Power Amplifier with neat diagram. [L2][CO3][5M]
 b) Write notes on crossover distortion in class B power amplifier. [L1][CO3][5M]
6. Describe the operation of a single tuned capacitive coupled amplifier with diagram and derive the expression for its centre frequency, Quality factor, Voltage gain and bandwidth. [L2][CO3][10M]
7. Discuss Double Tuned Amplifier with neat diagram and derive the expression for its bandwidth. [L2][CO3][10M]
8. a) A single tuned RF amplifier uses a transistor with an output resistance of $50\text{ K}\Omega$, output capacitance of 15 pF and internal resistance of next stage is $20\text{ k}\Omega$. The tuned circuit consists of 47 pF capacitance in parallel with series combination of $1\mu\text{H}$ inductance and 2Ω resistance. Calculate resonant frequency, effective quality factor and bandwidth of the circuit. [L3][CO3][5M]
 b) Explain the effect of cascading single tuned amplifiers on bandwidth. [L2][CO3][5M]
9. a) With circuit diagram, describe the stagger tuning operation. Give necessary graph. [L2][CO3][6M]
 b) The bandwidth for single tuned amplifier is 20kHz . Calculate the bandwidth if three such stages are cascaded. Also calculate the bandwidth for four stages. [L3][CO3][4M]
10. a) Discuss the stability considerations of a tuned amplifier. [L2][CO3][5M]
 b) Compare the different types of tuned amplifiers. [L2][CO3][5M]

UNIT IV

OPERATIONAL AMPLIFIER

I. Two Mark Questions:

1. What is operational amplifier? [L1][CO4][2M]
2. Mention the applications of operational amplifier. [L1][CO4][2M]
3. List the characteristics of an ideal opamp. [L1][CO4][2M]
4. Design an opamp with a gain of -10 and input resistance equal to $10\text{k}\Omega$. [L3][CO4][2M]
5. Design an amplifier with a gain of +5 using one opamp. [L3][CO4][2M]
6. Define CMRR. [L1][CO4][2M]
7. What are the important features of an instrumentation amplifier? [L1][CO4][2M]
8. Mention the differences between differentiator and integrator. [L1][CO4][2M]
9. Draw the output waveform of a differentiator for a sine wave input and square wave input. [L1][CO4][2M]
10. What is Scmitt trigger? [L1][CO4][2M]

II. Part – B Questions:

1. a) Draw an inverting amplifier using an opamp and derive the expression for its closed loop voltage gain. [L2][CO4][5M]
- b) In the figure shown, $R_1 = 10\text{k}\Omega$, $R_f = 100\text{k}\Omega$, $V_i = 1\text{V}$. A load of $25\text{k}\Omega$ is connected to the output terminal. Calculate (i) i_1 (ii) V_o (iii) i_L and (iv) total current i_o into the output pin. [L3][CO4][5M]

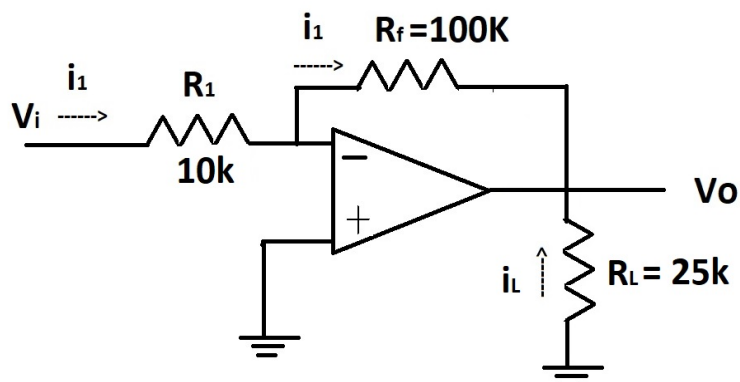

2. a) Draw a non inverting amplifier using an opamp and derive the expression for its closed loop voltage gain. [L2][CO4][5M]
- b) In the figure shown, $R_1 = 5\text{k}\Omega$, $R_f = 20\text{k}\Omega$, $V_i = 1\text{V}$. A load of $5\text{k}\Omega$ is connected to the output terminal. Calculate (i) V_o (ii) A_{CL} (iii) the load current i_L and (iv) the output current i_o indicating proper direction of flow. [L3][CO4][5M]

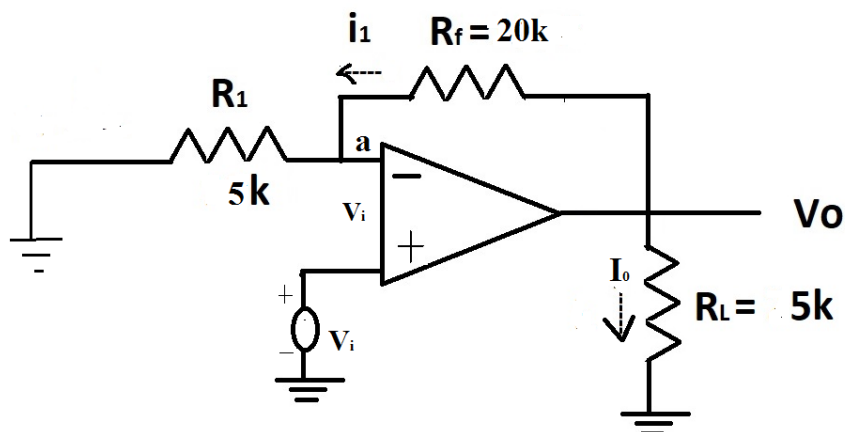

3. a) Draw the circuit diagram of a Differential Amplifier and derive the expression for its output voltage. Write about difference and common mode gains. [L2][CO4][6M]
- b) Explain the block diagram of an internal circuit of an operational amplifier. [L2][CO4][4M]
4. a) Describe the transfer characteristics of a differential amplifier. [L2][CO4][6M]
- b) Write notes on Scale changer with circuit diagram. [L1][CO4][4M]
5. Obtain the expression for output voltage for an non inverting summing amplifier and Subtractor. [L2][CO4][10M]
6. With neat circuit diagram, discuss instrumentation amplifier and also derive its output Voltage. [L2][CO4][10M]
7. a) What is sample and hold circuit? Mention the applications of sample and hold circuit. [L1][CO4][2M]
- b) Draw the circuit diagram of sample and hold circuit and describe its operation with the help of its input and output waveforms. [L2][CO4][8M]
8. a) What are the limitations of an ordinary opamp differentiator? [L1][CO4][2M]
- b) Draw the circuit diagram of ideal and practical differentiator and obtain the expression for their voltage gain. [L2][CO4][8M]
9. Draw the circuit diagram of an ideal and practical integrator. Derive the expression for their voltage gain. [L2][CO4][10M]
10. Explain the Schmitt Trigger with neat circuit diagram, input and output waveforms. [L2][CO4][10M]

UNIT V

OP-AMP APPLICATIONS

I. Two Mark Questions:

1. Define an electric filter. [L1][CO5][2M]
2. Classify active filters. [L1][CO5][2M]
3. Discuss the disadvantages of passive filters. [L1][CO5][2M]
4. Why are active filters preferred? [L2][CO5][2M]
5. What is Sallen-Key Filter? [L3][CO5][2M]
6. Mention the types of DACs. [L1][CO5][2M]
7. What are disadvantages of weighted resistor DAC? [L1][CO5][2M]
8. Why is an inverted R-2R ladder network DAC better than R-2R ladder DAC? [L2][CO5][2M]
9. List the various A/D conversion techniques. [L1][CO5][2M]
10. Define Settling time of a DAC/ADC. [L1][CO5][2M]

II. Part – B Questions:

- 1.a) Draw a First order low pass active filter and derive the transfer function its frequency response. [L2][CO5][5M]
b) Design a second order Butterworth low pass filter having upper cutoff frequency of 1KHz. [L3][CO5][5M]
2. Draw a general Sallen-Key Filter and determine its transfer function and from general Sallen Key Filter obtain the transfer function of second order active low pass filter. Draw second order active low pass filter. [L2][CO5][10M]
3. a) With a neat diagram of a second order high pass active filter, derive the expression for its transfer function. [L2][CO5][5M]
b) Design a second order Butterworth high pass filter having lower cutoff frequency of 1KHz. [L3][CO5][5M]
4. a) Classify Band pass filter. Mention the important parameters of a band pass filter. Draw a Second order narrow band pass filter and derive its transfer function. [L2][CO5][6M]
b) Design a high pass filter with cutoff frequency of 1 KHz and a pass band gain of 2. [L3][CO5][4M]
5. a) Draw a first order wide band pass filter and determine its transfer function. [L2][CO5][5M]
b) Design a wide band pass filter having $f_L = 400\text{Hz}$, $F_H = 2\text{KHz}$ and pass band gain of 4. [L3][CO5][5M]
6. a) What is a notch filter? How do we get a notch filter from a band pass filter? Draw the circuit schematic of a second order notch filter and obtain its transfer function. [L2][CO5][5M]
b) Design a wide band reject filter having $f_H = 400\text{ Hz}$ and $f_L = 2\text{KHz}$ having pass band gain of 2. [L3][CO5][5M]
7. a) Describe the operation of weighted resistor DAC with the help of circuit diagram. [L2][CO5][5M]
b) With suitable diagram, discuss R-2R ladder DAC. [L2][CO5][5M]
8. Draw the circuit diagram of inverted R-2R ladder DAC network. Explain its working. List out the advantages over R-2R ladder network. [L2][CO5][10M]
9. With neat circuit diagram and truth table, discuss flash type ADC. [L2][CO5][10M]
10. a) Draw and explain the circuit diagram of successive approximation ADC. [L2][CO5][8M]
b) Write the limitations of successive approximation ADC. [L1][CO5][2M]
11. a) Draw the circuit diagram of Dual Slope ADC and explain its working with neat sketches. [L2][CO5][8M]
b) What are the disadvantages of Dual Slope ADC? [L1][CO5][2M]
12. Explain the specifications of DAC/ADC specified by the manufacturers. [L2][CO5][10M]

Prepared by:

1. Dr. P.RATNA KAMALA
Professor/ECE
2. Mr M. AFSAR ALI
Professor/ECE